

Customized Solutions of the Industrial Automation Machines for the Rubber and Plastic industry

INDEX:

MOULDING

Department
Machines
Manipulators
and Robot

- .Trolley for picking and changing moulds
- .Pre-Heating oven
- .Brush manipulator, manipulator, Robot e Cobot

TREATMENT

Parts
Machines
Department

- .Rubber deflashing machine
- .Deburring machine
- . Cutting and deburring system
- .Automatic sorting with rotation rollers
- .Washing machine
- .Roto painter, Rototalcum, Rotosil and chlorination system

QUALITY

Control
Machines
Department

- .TMC— Manual Sorting table
- .NCL e NCLR Linear sorting belt with overturn of the pieces
- .Automatic vision inspection machines
Without Manipulation : AIR , ONE, TWO
With Manipulation: WAVE, STEP, PICKER

PACKAGING

And
SHIPPING
Machines
Department

- .Automatic weighing and packaging system
- .Stacker for rings ad filming device
- .Loading/Feeder systems

.Additional Loading parts System

Internal Logistic Automation Warehouse

Born with real passion for innovation

Fully Electric TROLLEY for Picking and CHANGING MOULDS for HORIZONTAL presses Cod. S1A

S1A Datasheet:

9 degrees of freedom / axes

Fully electric

CE marking

No movement / physical fatigue-total safety device

Molds size from 450 to 800 x 800 mm – size 250 or 400 kg max

UNIT / BRIGE for picking and CHANGING MOULDS INSIDE HORIZONTAL presses Cod. S1AA

S1AA Datasheet

BRIDGE unit with small internal lift, for the mould removed from the fixing bolts

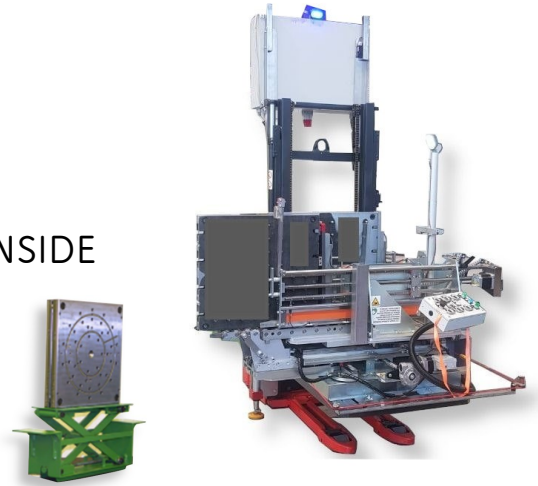

UNIT / TROLLEY TO CHANGE moulds for VERTICAL presses Cod. S1B

S1B Datasheet

Pick-up lifting e

deposit up to 2.5 meters

Weight up to 800 kg

Mould dimensions up to 900 x 900 x 500 mm



MOULD OPENING UNIT Cod. S2RM

S2RM Datasheet

Opening and management of the open mould

with 90 ° tilting system, 2 magnetic shelves

(horizontal and vertical)

Available also for large dimension moulds

washing tabs also optional

Plates from 300 to 700 mm and up to 50 mm of thickness



PRE-HEATING OVEN for MOULDS pre-assembly unit Cod. S3

Rubber

Datasheet

4 + 4 workstations of
parking area

Working contemporary for 8 worksta-
tions

Mould size up to 800 x 800

Controlled and adjustable temperature
up to 220°



2-axis robotic BRUSH MANIPULATOR for horizontal and vertical presses Cod.S4A

Datasheet Accessories:

- Rotating brush
- Typhoon blowing kit
- Flashing pick-up and detach-
ment unit.
- Extraction plate kit

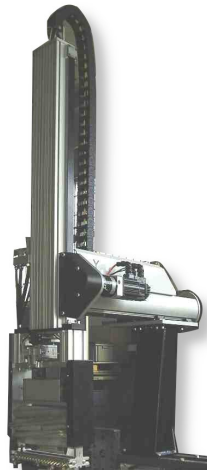

Parking trolley manipulator off press Cod. S4Z

Rubber & Plastic

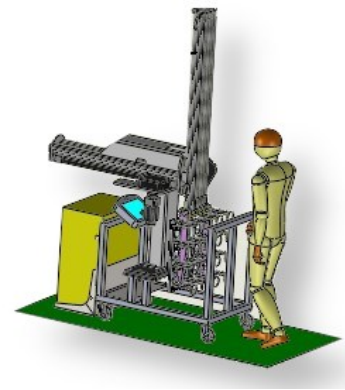

DOUBLE ROBOBRUSH – 1+1 single Brush Cod. S4A1

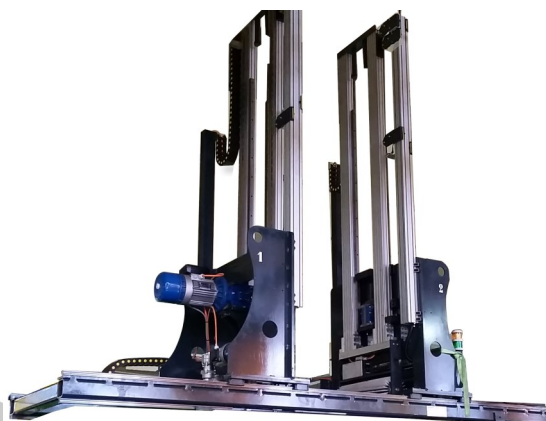

2-axis robotic MANIPULATOR with dedicated extraction PLATE for horizontal / vertical Presses Cod.S4A2



Semi Automatic Rubber DEFLASHING Machine Cod. T1A

Rubber & Plastic

Datasheet

Little deburring machine used for Small batch products

Without refrigeration air , only electricity

To be positioned near the presses



Deburring machine for complete mold obtained by stamping die Cod. T1A1

Rubber & Plastic

Datasheet

Fast hydraulic press for stamped blanking and / or die-cutting

Plate dimension 400 x 400 mm

Free height space 600 mm

Robot or Cobot applied to loading or unloading
and also possible application of visual control

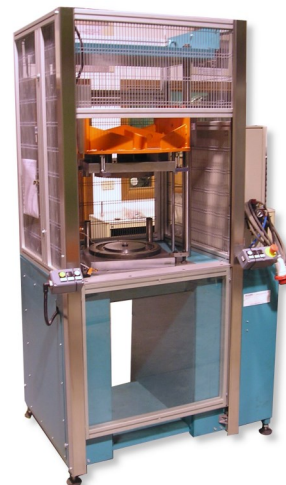

Automatic Sorting with rotating rollers Cod. T3B

Rubber & Plastic

Datasheet

Automatic SEPARATOR horizontal
rotating roller

Adjustable automatic load

Separation by rotating sectors
with adjustable spacing from 32
to 10 mm

Preset speeds

Also with touch screen and re-
cipes

Low coverage

Kw 2,5



WD Washing machine - Wash & Dry with rotating Drum Cod T2A

Rubber

T2A Datasheet

Stainless steel washing and Dry machine with front opening rotating basket

300 lt of product in operation / 6 boxes of 50 lts each

Washing with detergent, rinsing with high pressure water ,
drying with filtered air.

Disposable water

High productivity.

We have also a model without high pressure



Rotary DRUM batch philosophy

Washing machine WD – COCLEA Continuous Wash & Dry also for Pharma Cod.T2B

T2B Datasheet

Stainless steel washing machine with rotating AUGER and continuous cycle without stops

Built in compliance with the criteria of the machines in pharma sector

Wash 1 with detergent in a water bath, also hot water

Wash 2 / rinse, even hot water . Recirculating waters

Washing with high pressure, end of cycle with drying unit with filtered air

Disposable water

available Automatic weighing cell to fill boxes

High productivity

Low coverage

unadvised for little parts below 15 mm

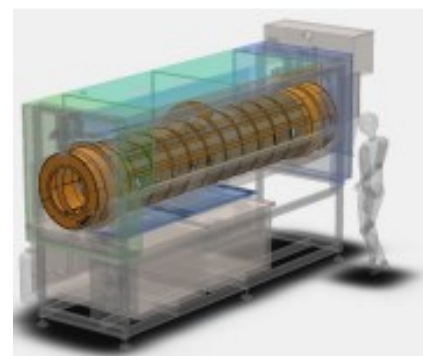

T2C Datasheet

Stainless steel washing machine with rotating auger and continuous cycle without stops, Wash 1 with detergent in a water bath, also hot water

Wash 2 / rinse, even hot water

Recirculating waters

Washing with high pressure, with drying unit with filtered air

Disposable water

Automatic weighing cell to fill boxes

High productivity

Low coverage



Rotary continuous COCLEA philosophy

Cod. T5A ROTO PAINTER LAB 20 SB Coming soon

Rubber & Plastic

Rubber & Plastic

ROTO PAINTER 90 WB – WATER Basic Lacs Cod. T5B

T5B Datasheet

Lacs and paint Water basic Coating System

Used to paint rubber gaskets or little parts with rotodrum philosophy.

With rotodrum cover , filtered air inlet , pre-heating oven , spray gun paint complete system , weight scale, touch screen , recipes, according to ATEX regulation

DRUM capacity : 30 or 60 or 90 lt in work

Facilited monitor display

ROTO PAINTER 90 SB – Solvent Basic Paints and Lacs Cod. T5C

T5C Datasheet

Lacs and paint Solvent basic Coating System

Used to paint rubber gaskets or little parts with rotobrum philosophy.

With rotodrum cover , filtered air inlet , pre-heating oven , spray gun paint complete system , weight scale, touch screen , recipes, according to AT.EX. regulation

DRUM capacity : 30 or 60 or 90 lt at work

RotoSil 90 lt Cod. T6B

T6B Datasheet

Silicon Coating System

Used to treat rubber gaskets with rotobrum philosophy.

With rotodrum cover , filtered air inlet , pre-heating oven , spray gun paint complete system , weight scale, touch screen , recipes

DRUM capacity : 30 or 60 or 90 lt in work

RotoTALCUM 300 lt Cod. T6A

T6A Datasheet

Silicon Coating System

Used to treat rubber gaskets with rotobrum philosophy.

With rotodrum cover , filtered air inlet , pre-heating oven , spray gun paint complete system , weight scale, touch screen , recipes

DRUM capacity : until 300 lts in work

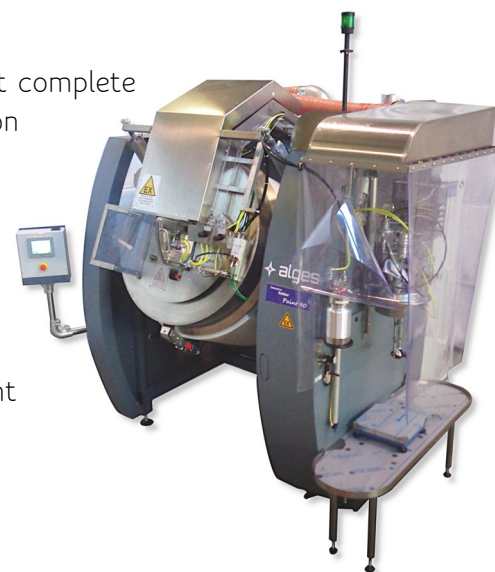

CHLORINATION SYSTEM for rubber gaskets Cod. T7A

Rubber & Plastic

Datasheet

CHLORINATION System

Used to treat rubber gaskets with washer immersion rotobrum philosophy.

With rotodrum cover , filtered air inlet , Dry heating unit, , touch screen , recipes

DRUM capacity : until 300 lts in work



TCM - Manual Sorting Table Cod. Q1A

Datasheet

Manual Sorting Table

The operator reverses the parts on the table and checks manually

Possibility to use in standing or sitting position

Movable Lamp or lens

Unloading slide



NCLeR - Linear Sorting Belt with OVERTURN of pieces Cod. Q1C

Datasheet

Feeder and sorting belt used to move little parts from feeder to

Visual operator inspection by :

- One operator on just one side

- Two operators on just one side

- Two operators on opposite sides

Parts flip on opposite side also

Adjustable speed, start and stop by foot

Weight scale

Range Parts : from 10 to 60 mm size x 20 mm H

System dimension : 2 x 1,2 x H 2 mts

Double Q1A TCM table production

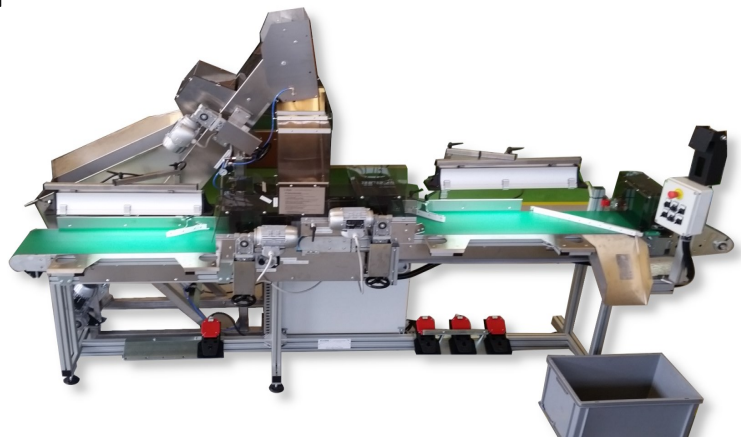

Special unit : visual inspection + automatic oil unit + automatic counter with release of oiled parts in buffer box

Cod. Q3B

Rubber, Plastic & Metal

V-Flex ONE Vision System

Datasheet : Single table machine with top, bottom through glass, peripheral external surface and dimensional inspection . For Pharma dept also . Until 10 parts for second , depending from parts



CONTROLLO ROTTURE	CONTROLLO DIMENSIONALE	CONTROLLO PROFILO	CONTROLLO SUPERFICIE	ORIENTAMENTO DEI PEZZI AL CARICO

Campo visivo [mm]	Ø60	Ø 80	Ø 100
-------------------	-----	------	-------

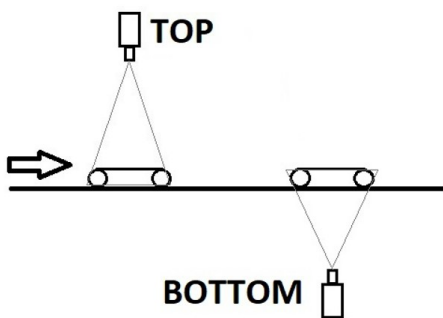

Check without contact

Cod. Q3C

Rubber, Plastic & Metal

V-Flex TWO

Datasheet
DOUBLE table machine with top, bottom, peripheral external surface insp. on T1 and peripheral external surface insp. on T2 and Dimensional

Until 10 parts for second , depending from parts



CONTROLLO ROTTURE	CONTROLLO DIMENSIONALE	CONTROLLO PROFILO	CONTROLLO SUPERFICIE	ORIENTAMENTO DEI PEZZI AL CARICO

Campo visivo [mm]	Ø60	Ø 80	Ø 100
-------------------	-----	------	-------

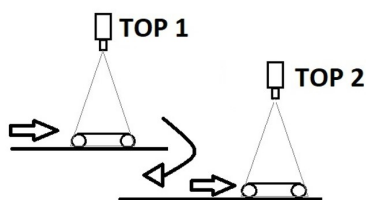

Check without contact

Cod. Q3A

Rubber, Plastic & Metal

AIR Vision System

Datasheet:

fast belt machine with overturning of the pieces ,
For Pharma dept also

Until 12 parts for second , depending from parts



CONTROLLO ROTTURE	CONTROLLO DIMENSIONALE	CONTROLLO PROFILO	CONTROLLO SUPERFICIE	ORIENTAMENTO DEI PEZZI AL CARICO

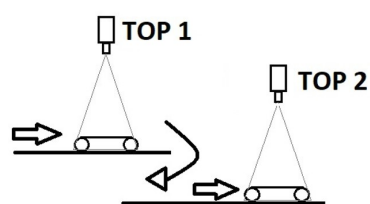

Check without contact



Cod. Q3F

Rubber, Plastic, Metal

PICKER Vision System

Datasheet

which picks up the rubber and rubber-metal rings with dia from 60 to 180 mm and performs the checks on the entire surface of the rotating piece

Upto 1800 parts / h, depending from parts

CONTROLLO ROTTURE	CONTROLLO DIMENSIONALE	CONTROLLO PROFILO	CONTROLLO SUPERFICIE	ORIENTAMENTO DEI PEZZI AL CARICO

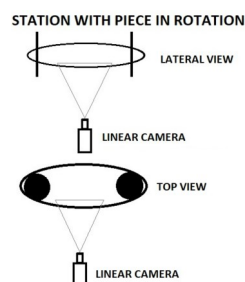
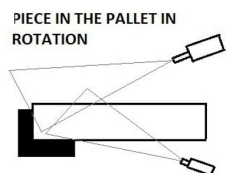

Check by handling



Rubber Parts COUNTER Machine Cod. PKC1

Rubber & Plastic

PKC1 Datasheet

Loading System applied to simple COUNTER device

Production : 6/8 parts each second = 20K / 30K parts each hour
(depending on diameter parts)

Parts range : from 10 to 70 mm OD

Optional :

Bags packaging system

Hopper table for box with bags counter each box

Automatic setup



RELEASE PACKAGING MACHINE Cod. PK7G2



Rubber Parts COUNTER machine (faster and safer) Cod. PKC2

Rubber & Plastic

Datasheet

Loading System applied to Vision system COUNTER device

Production : 10 parts each second = 25K / 35K parts
each hour (depending on diameter parts)

Parts range : from 10 to 50 mm OD

Optional :

Bags packaging system

Hopper table for box with bags counter each box

Automatic setup



STACKER for rings on card board pipes
(or without car board) LITTLE Table autonomy Cod. PK7CA

Rubber & Plastic & Metal

Datasheet

Automatic Loading system and stacker unit joint together

Rings Range: from ID 30 mm to 80 mm OD

Upto 20 shafts - 40 minutes autonomy each manual discharge filled pipes (depending on parts thickness And dimension)

Dimension system 2.7 mts x 1.8 mts



STACKER for rings on card board pipes
(or without car board) Higher Table autonomy Cod. PK7A 1

Rubber & Plastic & Metal

Datasheet

Automatic Loading system and stacker unit joint together

Rings Range: from ID 30 mm to 120 mm OD

Upto 46 shafts with 40 minutes autonomy each manual discharge filled pipes

Dimension system 3,5 mts x 2,5 mts



Fast STACKER for rings + Filming device (without card board pipe) included
Cod. PK7B1

Rubber & Plastic & Metal

Datasheet

Automatic Loading system and stacker unit joint together

WRAPPED Rings pipe in plastic soft film with stripper also

Rings Range: 30 to 200 mm OD

6 shafts in work

Dimension system 3,5 mts x 2,5 mts

Fast process in box frame



Alges Ethical philosophy and Guarantee of Confidentiality

Alges is committed to ensuring the utmost respect for the confidentiality of information, including engaging the entire team in compliance with signed non-disclosure agreements.

Alges Vision for the Future

Today, Alges' commitment is to meet the challenge of the global marketplace. The desire to promote our philosophies and platforms beyond the boundaries of our historical target markets is one of the company's priorities. We want to assist technically and with planning, with an excellent and punctual service, a growing number of customers, to consolidate the partnership with them. We are not only a supplier: we can, thanks to our high multi-sectoral competence, become part of the design - production and testing chain of our customers' products. The needs of the market will be our new challenges of the future.

Our Milestones:

Simple yet innovative solutions that enable:

- the increase of productivity
- User friendly solutions for operators
- the reduction of human error
- the simplification and flexibilization of operators' tasks

ALGES strengths

- 20 years of experience in mechanical engineering
- 20 years of process invention with multi-technology synergies
- 15 years of experience in machine vision
- 5 years of development of standardized customizable platforms
- 500+ installations of which 30% standard and 70% specials
- 15 years with strong relationship with strategic partners

Markets:

Alges works 50% in Italy, 50% foreign markets

Thanks!
**For the interest and
the time dedicated**



Phone : +39 030 7451099 a.r.

For IT : info@algesmac.it - sales@algesmac.it

For Abroad : export2@algesmac.it - export.de@algesmac.it

Website: www.algesmac.com - www.algesrobotautomation.com

www.smallpartscottingmachine.com - www.algesvisualinspectionmachine.com

Alges Address : Via lucerna , 8 - Adro 25030 (Brescia) - IT